



Heavy Duty incremental encoder

- ▶ Extremely robust housing for harsh environments
- ▶ 6 or 3 short-circuit protected outputs
1, $\bar{1}$, 2, $\bar{2}$, 0, $\bar{0}$ / 1, 2, 0
- ▶ IP 65, encapsulation class
- ▶ Electrically insulated hollow-shaft
- ▶ 5 Vdc or 9...30 Vdc
- ▶ Available with Advanced internal diagnostics, ADS



861

ELECTRICAL SPECIFICATION

Supply voltage +EV	9-30V	5V ± 10%
	Polarity protected	---
Current consumption at no load	60mA @ 24V Max 80mA	85mA Max 155mA
Line counts	1000, 1024, 2048, 2500, 3072, 4096, 5000	
Measuring steps	4 x Line counts	
Accuracy		
Dividing error	± 50° el	
Channel separation	90° ± 25° el	
Outputs	High current HTL	RS-422
	Short circuit protected	
Load max	± 40mA	± 20mA
Max cable length	350m @ 100kHz	1km (TIA/EIA-422-B)
U _{high} (at 40mA load)	> +EV - 4,0V	> 3,0V
U _{low} (at 40mA load)	< 2,5V	< 1,15V
Frequency range	0...100kHz	0...200kHz
Option	Advanced Diagnostic System ADS	
Alarm output	Opto-coupler	
OK	Closed-circuit	V _{CE} < 2V at 10mA
Error	Open-circuit	min 500ms
Voltage max	35V	
Current max	30mA	
PC communication	RS-232	Max 10m cable

ACCESSORIES

Torque arm	
M5	Part. No. 01208013
M6	Part. No. 01208014
ADS PC software kit	Part. No. 01209084

OUTPUT CIRCUIT

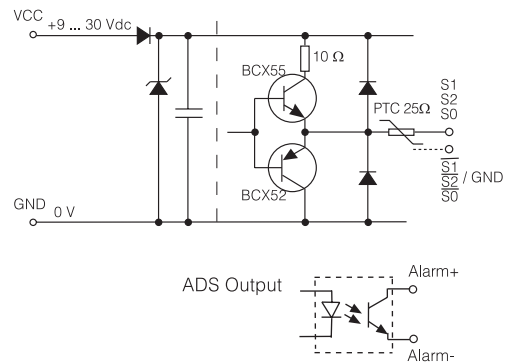

OUTPUT SIGNALS

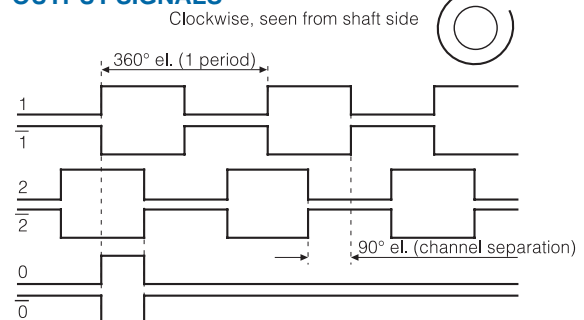

CONNECTION

Function	Terminal	12 pin EML	Colour
+ E Volt	1	12	Red
0 Volt	2	10	Blue
0	3	3	Brown
0 (0 Volt *)	4	4	Violet
1	5	8	Green
1 (0 Volt *)	6	1	White
2	7	5	Yellow
2 (0 Volt *)	8	6	Black
Alarm +	9	9	Grey
Alarm -	10	11	Pink
RXD	11	7	Grey / Pink
TXD	12	2	Red / Blue
Case			Shield

* 3 channel output
All 0 Volt pins are internally connected on the PCB

ADS outputs

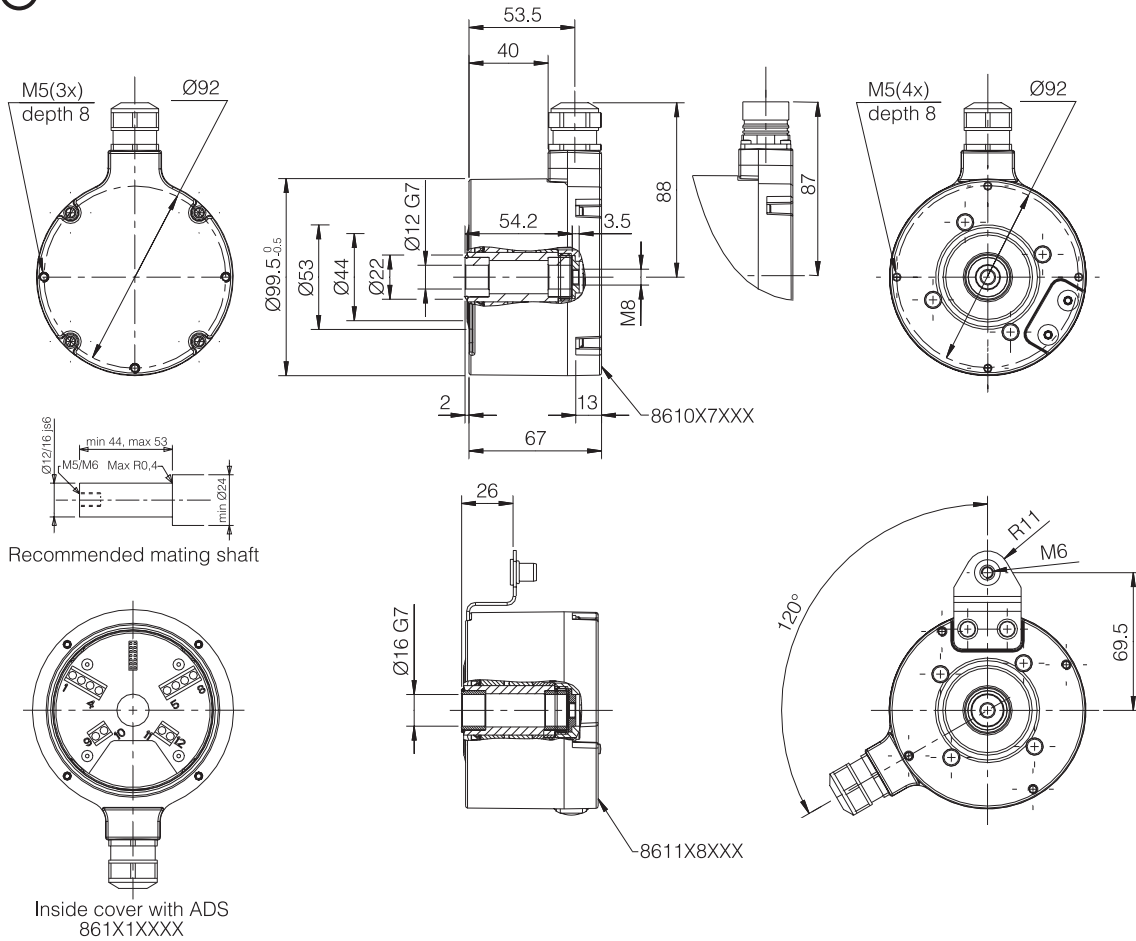

MECHANICAL SPECIFICATION

Isolated Hollow-shaft	Ø12, 16mm, Stainless steel / PEEK
Moment of inertia	55 x 10 ⁻⁶ kgm ²
Load max	
Radial	300N
Axial	100N
Speed max	4000 rpm
Code disc	Extended temp
Temperature	
Operating	-20°C ... +80°C
Storage	-25°C ... +80°C (+105°C max 1h)
Housing	Aluminum, coated
Weight	Approx. 1300g
Protection class	IP 65 according to IEC 529
Vibration	<100m/s ² (50...2000 Hz)
Shock	<1000m/s ² (11ms)
Cable	10x0,25mm ² twisted pair PVC (Not ADS)
Connector	12 pin EML

ORDERING INFORMATION

8 6 1 - [] [] [] [] [] [] - [] [] [] [] [] []

Option

Mechanical

- 0 = Standard
- 1 = Torque bracket (for M6 torque arm)

Electrical

- 0 = Standard
- 1 = ADS (1024, 2048 and 4096 ppr)

Hollow-shaft

- 7 = Ø 12 mm
- 8 = Ø 16 mm

Connection

- 2 = Connector, radial
- 3 = Cable, radial 1.5 m
- 4 = M20 cable gland, radial Ø8-11mm
- 5 = M20 cable gland, radial Ø11-14mm
- 9 = Cable, radial xx m

Supply voltage

- 1 = 5 Vdc (Not available with ADS)
- 5 = 9...30 Vdc

Outputs

- 5 = 3 channels 1, 2, 0
- 6 = 6 channels 1, 1, 2, 2, 0, 0

Line counts

1000, 1024, 2048, 2500, 3072, 4096, 5000 ppr (Other line counts on request)